



Home Gateway Initiative

1
2
3
4
5
6
7
8
9
10
11
12

Performance Metrics

Version 1.0

05/06/2008

1
2
3
4
5
6
7
8
9
10
11
12
13
14
15
16
17
18
19
20
21
22
23
24
25

PAGE LEFT INTENTIONALLY BLANK

1	Table of Contents	
2		
3	1	Important notice, IPR statement, disclaimer and copyright..... 4
4	2	Acronyms..... 5
5	3	Definitions and Terminology..... 6
6	4	Introduction and scope of the Home Gateway Initiative (HGI)..... 7
7	4.1	Cooperation with other bodies and initiatives..... 7
8	5	Introduction..... 8
9	6	Methodology..... 9
10	6.1	Configuration Profile..... 9
11	6.2	Test Setup..... 10
12	6.2.1	HG..... 11
13	6.2.2	WAN I/F..... 11
14	6.2.3	WAN/LAN Switch..... 12
15	6.2.4	Wi-Fi/HAN Test Setup..... 12
16	6.2.5	Test Equipment: IGMP Tester, Voice Tester, Traffic Generator/Sink..... 13
17	6.2.6	Interference with Test Setup..... 13
18	6.3	Test Procedure..... 13
19	6.3.1	Flooding Test..... 13
20	6.3.2	Headroom Test..... 15
21	7	References..... 17
22	Appendix	18
23		

1 **1 Important notice, IPR statement, disclaimer and**

2 **copyright**

3 The Home Gateway Initiative (HGI) is a non-profit making organization created to define
4 guidelines and specifications for broadband Home Gateways.

5 This document is the output of the Working Groups of the HGI and its members as of the
6 date of release. Readers of this document must be aware that it can be revised, edited or have its
7 status changed according to the HGI working procedures.

8 The HGI makes no representation or warranty on the contents, completeness and accuracy
9 of this publication.

10 This document, though formally approved by the HGI member companies, is not binding in
11 any part on the HGI members.

12 IPRs essential or potentially essential to the present document may have been declared in
13 conformance to the HGI IPR Policy and Statutes available at the HGI website
14 www.homegateway.org .

15 Any parts of this document may be freely reproduced (for example in RFPs and ITTs) by
16 HGI and non-HGI members subject only to the following:

- 17 • HGI Requirement numbers not being changed
- 18 • an acknowledgement to the HGI being given in the resulting document.

19 Trademarks and copyrights mentioned in this document are the property of their respective
20 owners.

21
22 The HGI membership list as of the date of the formal review of this document is: 2 Wire, Inc.,
23 Alcatel-Lucent, Atheros, AVM ,Belgacom, BeWAN, Broadcom, BT, Deutsche Telekom, DS2, DSP
24 Group, Echelon EMEA, ,Ericsson AB, Fastweb SpA, France Telecom, Freescale Semiconductor,
25 Gige Semiconductor, Huawei, InAccess Networks, Infineon Technologies AG, Intel, Intellon, ITRI,
26 JDSU, Jungo Software Technologies, KDDI, KPN, LG-Nortel Co Ltd, Linksys/Cisco, Marvell
27 Semiconductors, Microsoft, Motorola, Netgear, NTT, Philips, Pirelli Broadband Solutions, Portugal
28 Telecom, Sagem, Siemens, Sphairon Access Systems, Spidcom, Supportsoft, Swisscom AG,
29 Telecom Italia, Telefonica, Telekom Slovenije, Telekomunikacja Polska, Telenor, TeliaSonera,
30 Telkom ZA, Telstra, Texas Instruments, Thomson, Tilgin AB, TNO ICT, U4EA Technologies
31 Limited, Ubicom Inc., Vtech, ZTE, Zarlink, ZyXEL.
32

1 **2** **Acronyms**

2	ATA	Analog Telephone Adapter
3	BSP	Broadband Service Provider
4	DRAM	Dynamic Random Access Memory
5	DUT	Device Under Test
6	FE	Fast Ethernet
7	HAN	Home Area Network.
8	HG	Home Gateway
9	IPTV	Internet Protocol TeleVision
10	LAN	Local Area Network
11	PLC	Powerline Communication
12	PVR	Personal Video Recorder
13	STB	Set Top Box
14	QoS	Quality of Service
15	SoC	System On Chip.
16	VAS	Value Added Service (equivalent to Managed Service)
17	WAN	Wide Area Network
18		

1 3 Definitions and Terminology

- 2 • **Flooding**: A number of flows and functions applied to the HG that is in addition to the
3 normal usage model of flows and functions. The flooding is applied under a test
4 environment to determine the HG's ability to retain QoS of VAS.
- 5 • **Headroom**: Capacity of the solution that exists beyond what is required to transport and
6 enable a predefined set of VAS captured in a profile.
- 7 • **Value Added Service**: A service for which the BSP provides preferential treatment (that
8 can include QoS...) for the customer. The service can be a service offered by the BSP or
9 operated by the BSP on behalf of a third party. A managed service can also be local:
10 watching a video on a PC recorded on the IPTV STB; as explained in the IPTV PVR use
11 case. Managed services do not necessarily involve use of the remote management system;
12 management only means that the operator has taken some responsibility for the service
13 (e.g. its QoS treatment) in order to provide the appropriate quality of experience.
- 14 • **Profile**: A set of VAS, represented in terms of functions and traffic flows, applied to a
15 specified HG hardware configuration.
- 16 • **System-on-Chip**: A silicon chip composed of one or more processors with various
17 LAN/WAN interfaces, DRAM all interconnected with an internal bus.
18

4 Introduction and scope of the Home Gateway Initiative (HGI)

Home connectivity has evolved dramatically over recent times. From the initial simple voice service, home services evolved in the 80s to include things such as fax and video text, with the 90s seeing the advent of mass-market Internet access via dial-up modems. At the start of the 21st century, the world has entered the broadband era. Network operators have deployed technology that offers much larger bandwidths, such as DSL, cable or fibre-based access systems.

The Internet has been a major driver for the evolution to broadband, creating a new experience for the customer and offering him new services such as email and Internet browsing, and “online” versions of existing services such as digital photo labs, ticket booking etc.

The next generation of broadband services (triple or even “multiple-play”) has created a set of new requirements for the Home Gateway, namely:

- the need to manage the Home Gateway, and to a lesser extent, the home network and the devices beyond the Home Gateway
- allowing the right device or application to connect to the right service platform with the right service class / Quality of Service
- unifying device capabilities in order to offer customers a better “integrated home environment”.

Due to the lack of suitable off-the-shelf and standardized products to support this new, end-to-end network and service model, several major Telecom Operators have recently worked separately with a very small number of Home Gateway vendors to specify and develop suitable Gateways. However, such custom development is not cost-effective for either operators or vendors.

It became apparent that many operators had similar service aspirations, and so were asking for similar equipment. Therefore in December 2004, nine Telecom Operators founded the Home Gateway Initiative to agree on a common Gateway specification. The intention was to involve the relevant vendor community (i.e. vendors of gateways, chipsets, software, devices and transmission systems) so that the specifications would also be pragmatic and could be realized in a cost-effective manner.

The aim of HGI is therefore to specify a small range of low cost, high capability Gateways which will provide multi-service communication support for the residential and SOHO environments. While an end-to-end network view has been taken, the specifications mainly focus on the Home Gateway device which sits between the access network and service platforms on one side, and the in-home networked devices and applications on the other.

4.1 Cooperation with other bodies and initiatives

The Home Gateway Initiative does not wish to become a new, long-term de facto standardization body. Its task is to agree a set of functional requirements for a Home Gateway, wherever possible re-using or referring out to existing specifications. An important aspect of the work is to identify gaps and inconsistencies in or between existing specifications. The HGI will publish its own specifications, but will work alongside other SDOs to ensure that issues are addressed in the most appropriate body, that there is no unnecessary duplication of effort, and that the HGI specifications are downstreamed in the most appropriate way.

1 **5 Introduction**

2 This document gives an overview of the HGI performance metrics, capturing the objectives,
3 and defining the process, methodology, test setup and resulting graphs that represent a HG
4 performance capability.

5 The objective of the performance metrics is to define a way of evaluating the performance
6 capabilities of the HG in an environment that closely represents what is found in a real deployment.

7 A HG typically has a SoC device that performs most of the HG functions. Within the SoC is a
8 processor. Historically, a common way of communicating the capability of the processor was to
9 either identify the clock frequency (MHz), or the instructions per second (MIPS) or some calculation
10 metric (e.g. Dhrystone). All these metrics have no association to the functions and flows that a HG
11 has to process.

12 Assessment of processors has evolved and a group called EEMBC [2] have developed
13 many application specific tests such as NAT, IP packet processing, and QoS. These tests require
14 specific code to be applied to enable comparison of processor technologies. However, these tests
15 represent a small subset of the overall HG functions [1], and the algorithms specified in the tests
16 are not 100% applicable to the functions found in a HG [1]. Thus, the EEMBC metrics are
17 unsuitable for HGI performance metrics.

18 The performance metrics outlined in this document answer the question of whether a HG is
19 able to meet the minimum service requirements, including any QoS metrics, whilst being under
20 duress. Once the HG meets the minimum requirements, the next goal of the performance metric is
21 to ascertain how much processing capacity remains. This additional capacity represents the
22 headroom that could be applied to future flows or functions yet to be defined by the BSP.

23 The performance metric must be measured in an environment that represents real world
24 situations.

25 The process and methodology must be defined such as it is specific to neither LAN/WAN
26 technology, nor services. This is to ensure that the performance metric can be applied to as many
27 different HG profile configurations as possible.

28 The resulting outputs must be informative and capture key behaviours of the HG. It is
29 expected that a single performance number is insufficient.

30 It is not the intent of the HGI's performance metric to ascertain the throughput capacity of
31 interconnected technologies, such as 802.11, PLC, and xDSL. This is left to the defining bodies of
32 such technologies such as Wi-Fi alliance and DSL Forum.

33

6 Methodology

6.1 Configuration Profile

It is recognized that there are many LAN and WAN technologies, in addition to the number of flows applied to the HG as well as the number of different functions required by the HG. It is impossible to capture all combinations in a single test environment. The concept of a profile is adopted. A profile defines a single set of VAS, represented in terms of functions and traffic flows, applied to a single and specified HG hardware configuration. The performance metric is applied to this profile. Multiple profiles will have to be created to capture all the different HG definitions as specified in [1].

The profile is made up of two components, physical and function/flows. The physical component defines the interfaces of the HG. Devices attached to the HG should also be defined to provide the necessary context in how the HG is to be used. The following diagram illustrates one example of the physical definition of a profile.

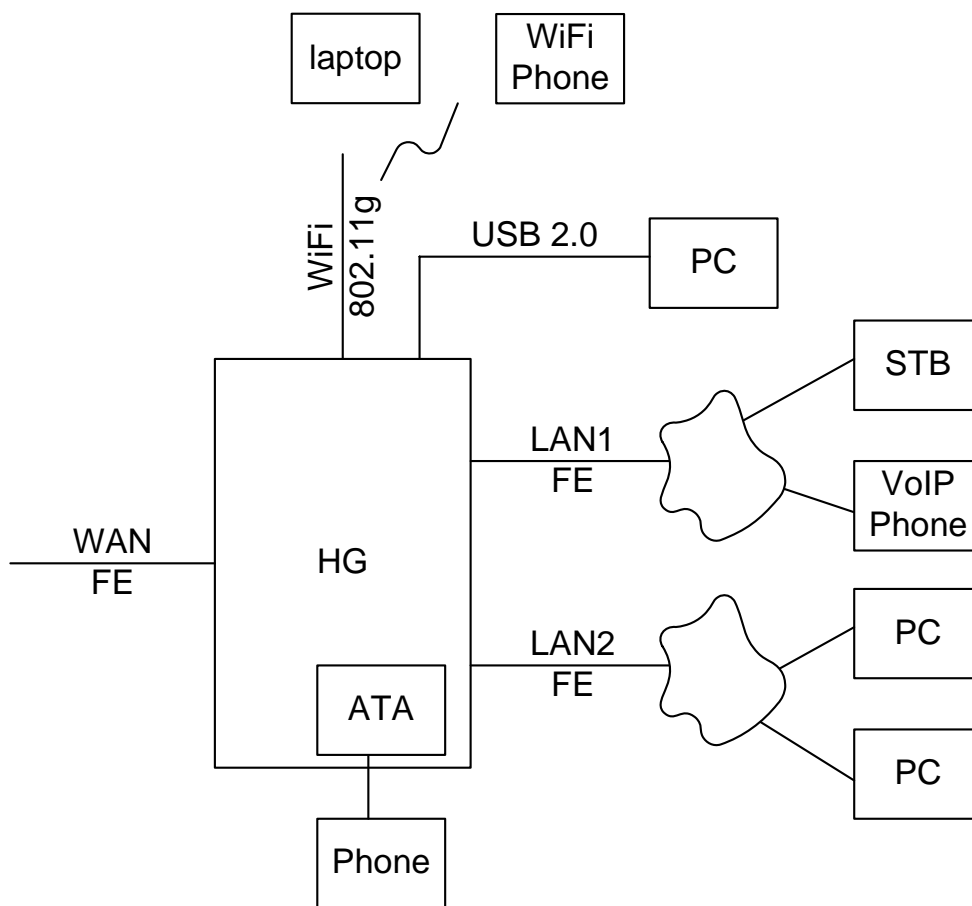

14
15
16
17

Figure 1 Physical definition of a profile

1 The function/flow component of the profile is a detailed list of functions and flows that the HG
2 has to perform and transport respectively. Examples of a flow include video, voice, and best effort.
3 Details of each flow are to be provided, such as packet rate/size, source/destination, initial DSCP
4 markings, required QoS metrics (acceptable loss rate, latency, jitter). In addition, transit functions
5 that impact performance must be captured. Examples of transit functions include DSCP
6 remapping, PPP termination, and NAPT/bridging.

7 Functions that have no association with a flow may be specified if that function is considered
8 to have impact on the performance of the HG. Not all flows or functions need to be captured in the
9 profile; only those functions/flows that impact the performance of the HG should be specified. An
10 example of a function/flow component of a configuration profile is included in the Appendix.

11 **6.2 Test Setup**

12 It is expected that many of the profiles will have multiple divergent flows. At the time of
13 writing, no single test equipment is known to be capable of generating/sinking/analysing all the
14 flows simultaneously; hence it is expected that multiple test equipment needs to be simultaneously
15 connected to the HG to realize the test.

16 The diagram below outlines the basic setup that enables the connection of various test
17 equipment that would provide the necessary stimulus and analysis to the HG. The basis of the test
18 assumes that the underlying L2 PHY technology is Ethernet. The motivation is to leverage the
19 widely available Ethernet based test equipment.

20 To maintain clarity in the diagram, not all flows are represented, such as those flows
21 terminated in the HG.

22 The motivation and function of each block within the test setup is described in the following
23 sections.

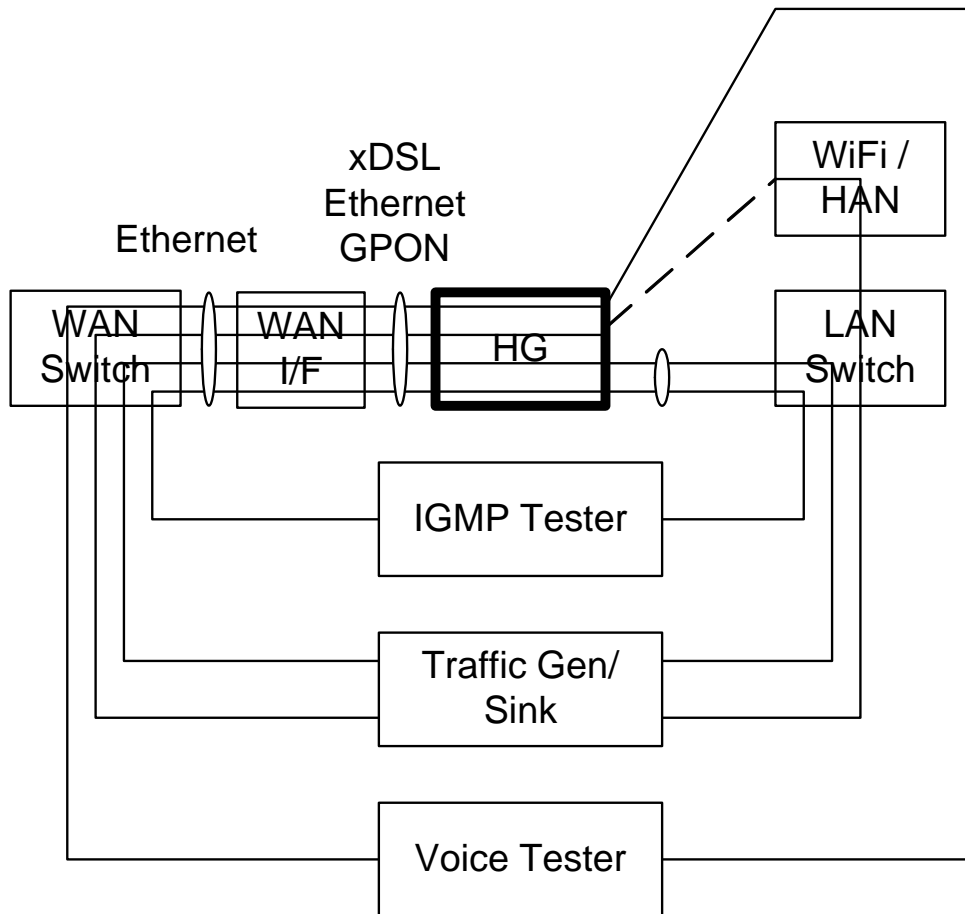

Figure 2 Example of test setup

1
2
3
4

5 **6.2.1 HG**

6 This is the HG as defined in HGI Residential profile v1 [1], and is the DUT.

7

8 **6.2.2 WAN I/F**

9 The WAN interface block found in the diagram represents the layer 1 bridging required
10 between the Ethernet based test equipment and the specific WAN interface configuration of the
11 HG. For HG, where the WAN interface is Ethernet, this block is a NULL function. For WAN I/F that
12 is Ethernet/ATM/DSL, this block is an IP DSLAM with an Ethernet uplink. In the case of GPON, the
13 WAN I/F is an OLT with an Ethernet uplink. In the case where Ethernet does not exist on the WAN
14 I/F, such as PPPoA/DSL, the WAN I/F consists of an ATM based DSLAM with a PPPoA termination
15 box (with appropriate PPP authentication) that has an Ethernet backend.

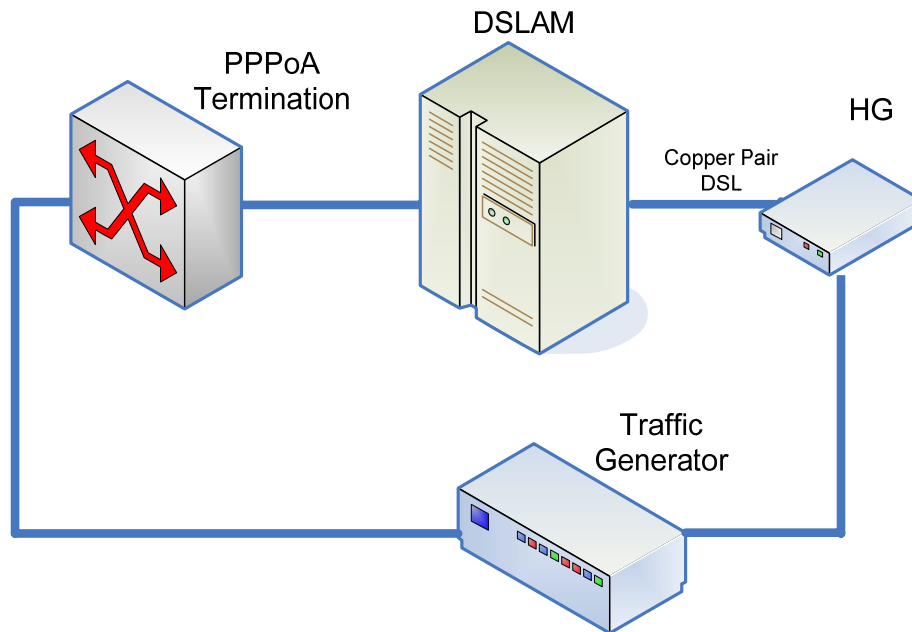

Figure 3 Example of PPPoA test setup

Common to all these WAN I/F devices is that Ethernet must be the L2 protocol to facilitate connectivity to the Ethernet based test equipment.

6.2.3 WAN/LAN Switch

The WAN/LAN Ethernet switches are components used to converge/distribute the Ethernet based flows to/from the various test equipment. Both switches must be capable of non-blocking switching across the range of packet sizes and rates utilised in the tests. In order to test the HG across a full range, the test setup must be capable of offering traffic into the HG at as close as possible to line rate. The LAN switch in this test setup may be the switch found in the HG. Should a switch not exist in the HG, then an external LAN switch may be required.

6.2.4 Wi-Fi/HAN Test Setup

To achieve reproducible and comparable test results, it is important that the Test Setup for the Wi-Fi/HAN part follows strict definitions. In addition to the definition of the common and well known Wi-Fi parameters the Test Setup must take into account the test environment as well. The following bullets describe the general setup:

- The distance between HG and Wi-Fi/HAN-Adapter must be 1m. This distance is short enough so that the antenna orientation or HAN medium should not have any impact on the system performance. Shorter distances might cause receiver blocking or overloading.
- There must be no obstacles in-between.
- QoS must be switched on.
- It must be verified that the environment is “clean”, that means there should be no interferers operating on the actual or neighbouring channels. Alternatively the Wi-Fi/HAN part of the setup can be placed in a shielded room.

- 1 • Specific to Wi-Fi:
- 2 • For the Test Setup HG and Wi-Fi Adapter must be configured to channel 4 (should
- 3 be supported in every country)

4

5 **6.2.5 Test Equipment: IGMP Tester, Voice Tester, Traffic Generator/Sink**

6 There can be one or more test equipment that is simultaneously required in the test setup.

7 Specialized test equipment such as the IGMP or voice tester may be required in the profile. Such

8 equipment is connected to the DUT via the LAN and WAN switches.

9

10 **6.2.6 Interference with Test Setup**

11 Given that the test equipment is typically NOT connected directly to the HG, care must be

12 taken that any device/component that sits between the HG and the tester are as transparent as

13 possible.

14 In the case of the switch, it is the convergence/distribution point for the majority of the flows

15 originating/destined for the testers. The switches output scheduler on the interface connected

16 directly to the HG will impact the latency/jitter QoS parameters for traffic, such as voice. The

17 overall buffer capacity of the switch will certainly impact transient responses of traffic coming

18 simultaneously from the testers. If the buffer is insufficient to withstand the transient bursts,

19 packets will be discarded in the switch. Hence the behaviour of the switch must be acknowledged

20 and the actual test procedure should attempt to eliminate interference of the switch's behaviour. In

21 addition, in-test monitoring of switch performance, such as packet discards, must be performed.

22 For layer 1 technologies that are susceptible to interference, such as the DSL, Wi-Fi and

23 HAN, care must be taken to eliminate all possible agitators that could change the outcome of the

24 test. Ideal layer 1 environments must be created to ensure that the performance of the HG is

25 measured, and not impacted by any layer 1 interference outside of the HG.

26

27 **6.3 Test Procedure**

28 The performance metrics has two distinct tests. The first test is called the flooding test, and

29 its objective is to capture the QoS behaviour of the HG under duress. This test establishes how

30 well a HG can maintain QoS of the VAS as defined in a profile, under a variety of conditions.

31 The second test is called the headroom test. Its objective is to quantify how much

32 processing capacity and throughput above and beyond what is required to be delivered to the VAS

33 as defined in a profile.

34

35 **6.3.1 Flooding Test**

36 Within the profile, the flows fall into one of two categories. There are the basic flows and the

37 flooding flows. The basic flows represent the bulk of the flows within the profile. These are the

38 flows that the HG must process and they define the minimum capability required by the HG. The

39 flooding flows are the aggregate upstream and downstream flows that put the HG under duress

40 The packet size of all flooding flows is set to 64B.

41 The procedure of the flooding test is as follows.

- 42 1. The basic flows are applied to the HG.

- 1 2. QoS metrics as specified in the profile are checked and confirmed that they have been
2 met.
- 3 3. The flooding flows are applied in addition to the basic flows. The ingress flood rate is
4 increased. There are four points of interest: when there is zero flooding, ingress flood rate at the
5 point of first discard, ingress flood rate at the point of maximum throughput and finally the ingress
6 flood rate when line rate is achieved.
- 7 4. At each point of interest, the test is run for one minute. During this time, minimum,
8 average and maximum latency values for flows that have latency QoS metrics are measured. In
9 addition, the average data rate for each flow is measured.
- 10 5. A graph is plotted, the X-axis records the ingress flood rate. The positive Y-axis plots the
11 average output data rate of each flow. The negative Y-axis captures the min/avg/max latency of
12 the latency sensitive flows. The x-axis only indicates the increase of ingress flood rate and the
13 basic flow rates are constant (ingress and egress).

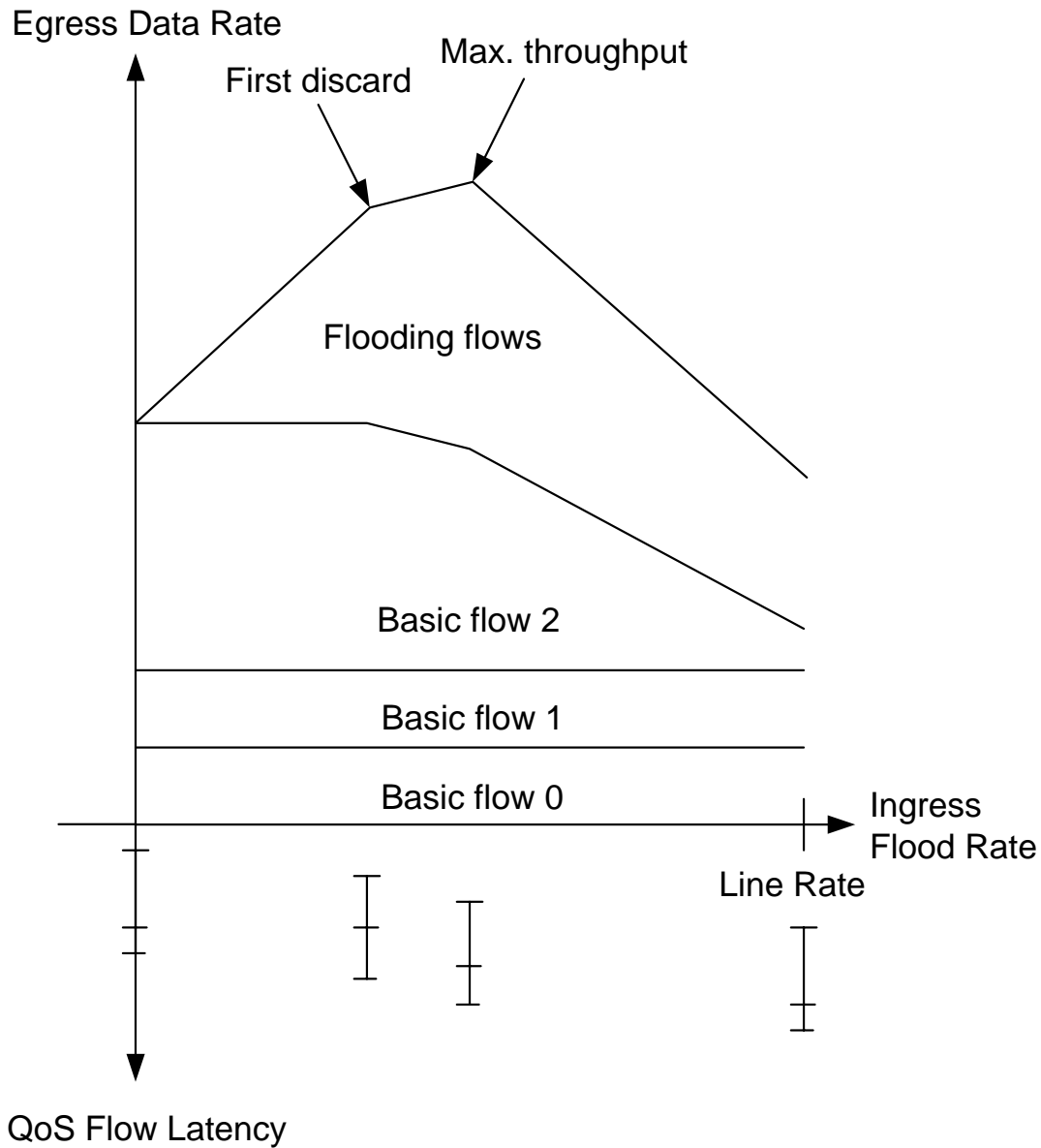

1
2 Figure 4 Example of graphical output from flooding test
3
4

5 **6.3.2 Headroom Test**

6 Within the profile, the flows fall into one of two categories. There are the basic flows and the
7 headroom flows. The basic flows represent the bulk of the flows within the profile. These are the
8 flows that the HG must process and they define the minimum capability required of the HG. The
9 headroom flows are the flows used to quantify the headroom capacity of the HG.

10 The procedure of the headroom test is as follows.

1 **7** **References**

- 2 [1] Home Gateway Technical Requirement, Residential Profile Version 1.0.1;
3 http://www.homegateway.org/publis/HGI_V1.01_Residential.pdf
4 [2] Embedded Microprocessor Benchmark Consortium, <http://www.eembc.org>
5
6
7
8
9

1 Appendix

2

3 The following table shows an example of a function/flow component of a configuration profile as
4 described in Chapter 6. It is constructed from a library containing a large set of flow definitions. This
5 library is given on the next page.

6 The library of flows is provided for convenience and can be used to develop configuration
7 profiles that accommodate a variety of application scenarios. For example, a configuration profile
8 could use High Definition (HD) or Standards Definition (SD) video flows, G.729 voice, IGMP, and
9 other flows as appropriate given the application context. For each flow within the library, packet
10 size, average bit rate, traffic pattern, protocol, and several other parameters are provided. Some
11 flows are used for flooding, some for headroom, and some for both. Some flows are basic, and
12 some are specific headroom flows or flooding flows.

13 A profile can be developed by selecting a number of flows from the library. The test
14 equipment used for this profile should be configured to provide each of the selected flows according
15 to the parameters shown in the flow library.

16 The example configuration profile (“profile 1”) provides flows for a triple play scenario. In this
17 particular profile, flows include:

- 18 • several WAN to HG flows
 - 19 ○ SD video
 - 20 ○ voice
- 21 • several WAN to LAN flows
 - 22 ○ IGMP
 - 23 ○ best effort basic
 - 24 ○ best effort headroom
 - 25 ○ best effort flooding
 - 26 ○ best effort (Bit Torrent) basic
- 27 • Several WAN to WIFI flows
 - 28 ○ Best effort (Bit Torrent) basic
 - 29 ○ Voice transit basic
- 30 • Several WIFI to WAN flows
 - 31 ○ Best effort (Bit Torrent) basic
 - 32 ○ Voice transit basic
- 33 • Web interface function

